

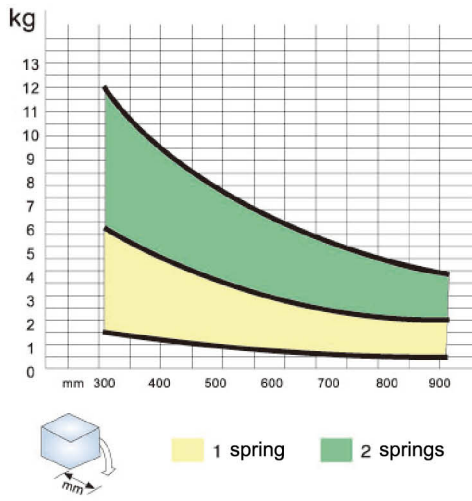

| Support Series

GAS SPRING

Support capacities



Pipe diameter: 15 x 1.00 mm

Rod diameter: \varnothing 6mm

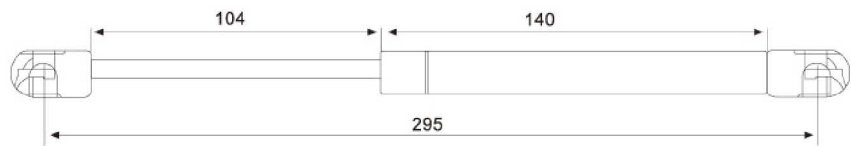
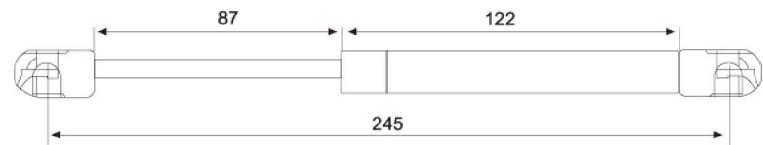
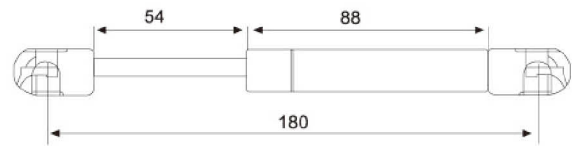
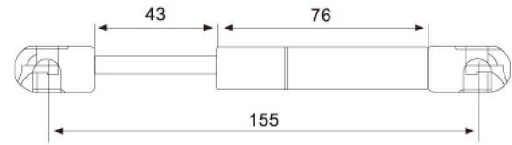

Specific Parameter:

Product	Length mm	Trip mm	In to the mm	Item No.
6"	77	43	155	541.111.000
8"	88	54	180	541.211.000
10"	122	87	245	541.311.000
12"	140	104	296	541.411.000

GAS SPRING

WA2001

Support capacities

Technical specifications :

Material: SPCC + Cu + NBR
 Color: silver / black / matte / gray / Gold, etc
 (Which can be customized according to customer demand for color)
 Treatment process: electroplating / spraying
 Installation: side installation
 Package quantity: 100 pcs / box

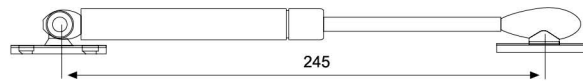

Usage:
 Each model can cause up Pneumatic Support(a section of power),Hydraulic Support(two section of power),Downward Hydraulic Support and Free Stop Pneumatic Support.

Accessories parameters:

A3

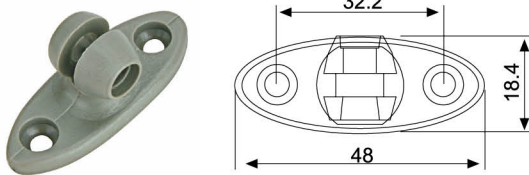

A6

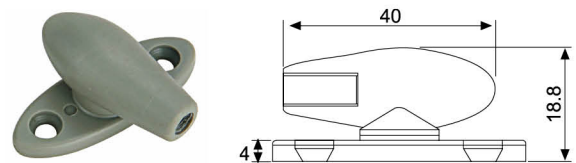

Specification, Size, Door, Choice:

Newton		80	100	120	140	Item No.
statis	Door Hight	Door weight, Newton				
80°	300	≤2.6	≤3.3	≤4.0	≤4.7	541.111.001
	400	≤2.2	≤2.7	≤3.3	≤3.9	541.121.001
	500	≤1.7	≤2.2	≤2.6	≤3.2	541.131.001
	600	≤1.3	≤1.6	≤2.0	≤2.5	541.141.001
90°	300	≤2.4	≤3.0	≤3.6	≤4.2	541.211.001
	400	≤2.1	≤2.5	≤3.0	≤3.5	541.221.001
	500	≤1.6	≤2.0	≤2.4	≤2.8	541.231.001
	600	≤1.2	≤1.5	≤1.8	≤2.1	541.241.001
100°	300	≤2.1	≤2.6	≤3.2	≤2.8	541.311.001
	400	≤1.7	≤2.2	≤2.6	≤3.2	541.321.001
	500	≤1.4	≤1.7	≤2.1	≤2.5	541.331.001
	600	≤1.0	≤1.3	≤1.6	≤1.9	541.341.001

Specification, Size, Door, Choice

www.meaton-group.com

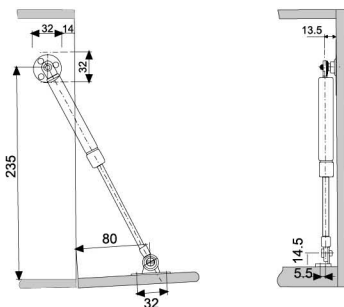

WA3001

Eliminate Noise To Design,Walk Slowly In The Whole Journey.
 Buffer Quality Assurance 50.000 Times.

D

Support Series

Support capacities

Technical specifications :



Material: SPCC + Cu + NBR
 Color: silver / black / matte / gray / Gold, etc
 (Which can be customized according to customer demand for color)
 Treatment process: electroplating / spraying
 Installation: side installation
 Package quantity: 100 pcs / box

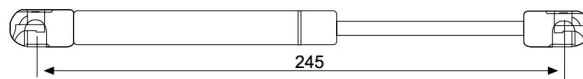

Optional Accessories

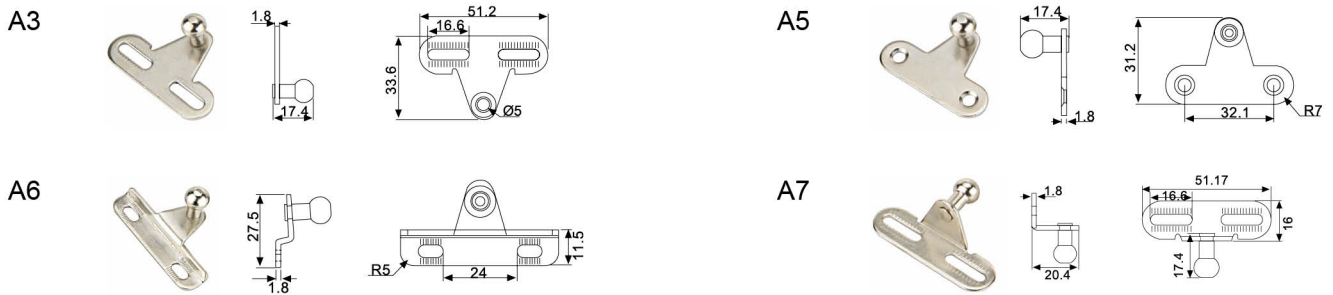

Specification, Size, Door, Choice:

Newton		80	100	120	140	Item No.
statis	Door Hight	Door weight, Newton				
80°	300	≤2.6	≤3.3	≤4.0	≤4.7	541.111.002
	400	≤2.2	≤2.7	≤3.3	≤3.9	541.121.002
	500	≤1.7	≤2.2	≤2.6	≤3.2	541.131.002
	600	≤1.3	≤1.6	≤2.0	≤2.5	541.141.002
90°	300	≤2.4	≤3.0	≤3.6	≤4.2	541.211.002
	400	≤2.1	≤2.5	≤3.0	≤3.5	541.221.002
	500	≤1.6	≤2.0	≤2.4	≤2.8	541.231.002
	600	≤1.2	≤1.5	≤1.8	≤2.1	541.241.002
100°	300	≤2.1	≤2.6	≤3.2	≤2.8	541.311.002
	400	≤1.7	≤2.2	≤2.6	≤3.2	541.321.002
	500	≤1.4	≤1.7	≤2.1	≤2.5	541.331.002
	600	≤1.0	≤1.3	≤1.6	≤1.9	541.341.002

Specification, Size, Door, Choice

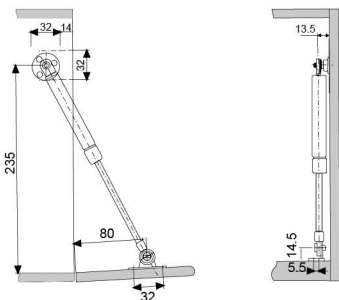

WA3002

Eliminate Noise To Design,Walk Slowly In The Whole Journey.
 Buffer Quality Assurance 50.000 Times.

GAS SPRING

WA2004

Support capacities

Technical specifications :



Material: SPCC + Cu + NBR
 Color: silver / black / matte / gray / Gold, etc
 (Which can be customized according to customer demand for color)
 Treatment process: electroplating / spraying
 Installation: side installation
 Package quantity: 100 pcs / box

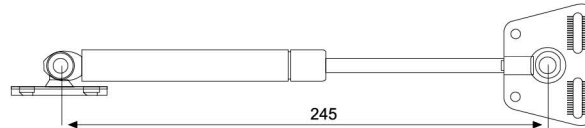

Optional Accessories

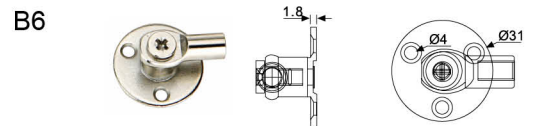
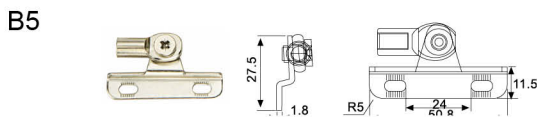
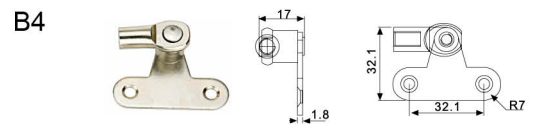
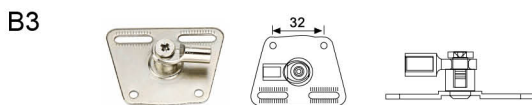

Specification, Size, Door, Choice:

Newton		80	100	120	140	Item No.
80°	Door Hight	Door weight, Newton				
	300	≤2.6	≤3.3	≤4.0	≤4.7	541.111.003
	400	≤2.2	≤2.7	≤3.3	≤3.9	541.121.003
	500	≤1.7	≤2.2	≤2.6	≤3.2	541.131.003
90°	300	≤2.4	≤3.0	≤3.6	≤4.2	541.211.003
	400	≤2.1	≤2.5	≤3.0	≤3.5	541.221.003
	500	≤1.6	≤2.0	≤2.4	≤2.8	541.231.003
	600	≤1.2	≤1.5	≤1.8	≤2.1	541.241.003
100°	300	≤2.1	≤2.6	≤3.2	≤2.8	541.311.003
	400	≤1.7	≤2.2	≤2.6	≤3.2	541.321.003
	500	≤1.4	≤1.7	≤2.1	≤2.5	541.331.003
	600	≤1.0	≤1.3	≤1.6	≤1.9	541.341.003

Specification, Size, Door, Choice

www.meaton-group.com

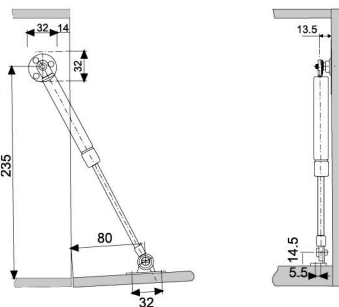

WA3004

Eliminate Noise To Design, Walk Slowly In The Whole Journey.
 Buffer Quality Assurance 50,000 Times.

D

Support Series

Support capacities



Technical specifications :

Material: SPCC + Cu + NBR
 Color: silver / black / matte / gray / Gold, etc
 (Which can be customized according to customer demand for color)
 Treatment process: electroplating / spraying
 Installation: side installation
 Package quantity: 100 pcs / box



Zonings:
 Each model can cause up Pneumatic Support(a section of power),Hydraulic Support(two section of power),Downward Hydraulic Support and Free Stop Pneumatic Support.

Optional Accessories

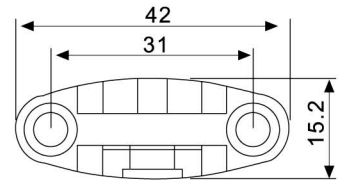
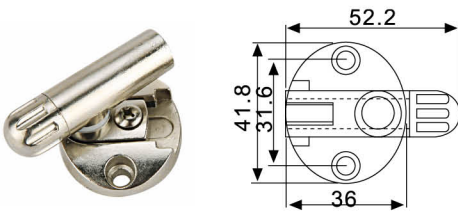

Specification, Size, Door, Choice:

Newton		80	100	120	140	Item No.
statis	Door Hight	Door weight, Newton				
80°	300	≤2.6	≤3.3	≤4.0	≤4.7	541.111.004
	400	≤2.2	≤2.7	≤3.3	≤3.9	541.121.004
	500	≤1.7	≤2.2	≤2.6	≤3.2	541.131.004
	600	≤1.3	≤1.6	≤2.0	≤2.5	541.141.004
90°	300	≤2.4	≤3.0	≤3.6	≤4.2	541.211.004
	400	≤2.1	≤2.5	≤3.0	≤3.5	541.221.004
	500	≤1.6	≤2.0	≤2.4	≤2.8	541.231.004
	600	≤1.2	≤1.5	≤1.8	≤2.1	541.241.004
100°	300	≤2.1	≤2.6	≤3.2	≤2.8	541.311.004
	400	≤1.7	≤2.2	≤2.6	≤3.2	541.321.004
	500	≤1.4	≤1.7	≤2.1	≤2.5	541.331.004
	600	≤1.0	≤1.3	≤1.6	≤1.9	541.341.004

Specification, Size, Door, Choice

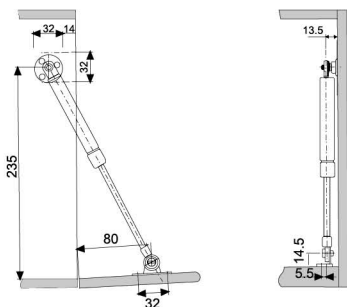

WA3007

Eliminate Noise To Design,Walk Slowly In The Whole Journey.
 Buffer Quality Assurance 50.000 Times.

Support capacities



Technical specifications :

Material: steel+plastic
 Finish: painting
 Capacity range: 50N-150N
 Available: up-turning wooden door and aluminum-frame

- Advantages:
1. Force adjustable
 2. Soft closing



Self-innovation plate wheel adjustable buffer-prevent the buffer from falling off due to turning

Parameter: WA2008

Pip diameter(mm)	Rod diameter(mm)	Length(mm)	Hole Distance(mm)	Stroke(mm)	Standard pressure(mm)	Item No.
∅ 15	∅ 6	312	282	92	50-150N	541.111.005



Technical specifications :

Material: steel+plastic
 Finish: painting
 Capacity range: 50N-150N
 (Piston with open & close buffering function is customized)
 Available: up-turning wooden door and aluminum-frame

- Advantages:
- Slight soft closing, force non-ajustasle

Parameter: WA2009

Pip diameter(mm)	Rod diameter(mm)	Length(mm)	Hole Distance(mm)	Stroke(mm)	Standard pressure(mm)	Item No.
∅ 15	∅ 6	281	266	90	50-150N	541.111.006

Support capacities

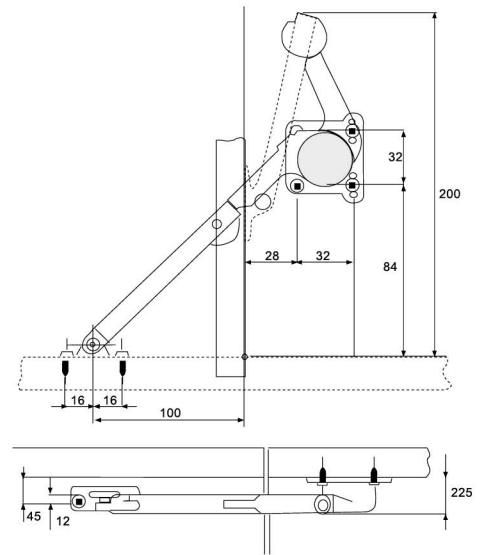

Technical specifications: WB4001

Material: zinc alloy

Color	Item No.
Nickel plated	542.116.000
Chrome plated	542.117.000

Downward opening stays
Left or right

D

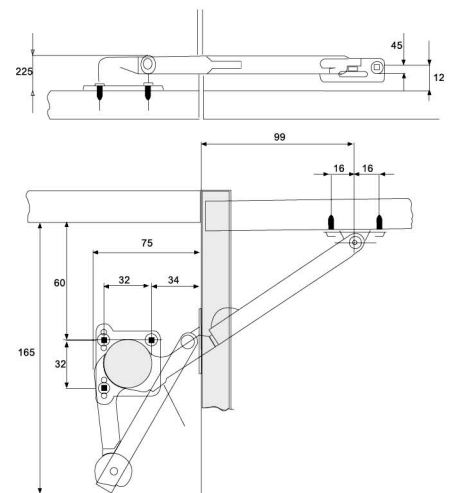
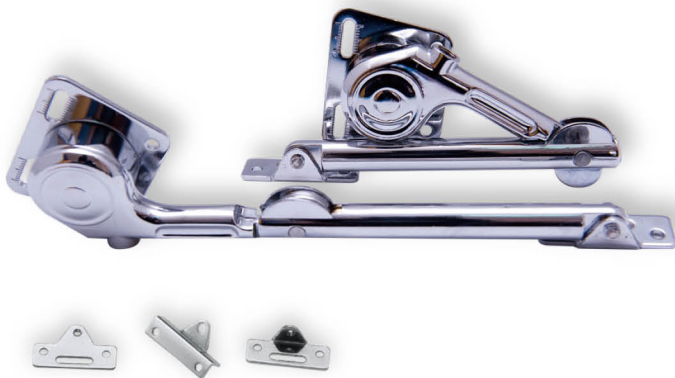

Technical specifications: WB4002

Material: zinc alloy

Color	Item No.
Nickel plated	542.116.001
Chrome plated	542.117.001

Upward opening stays or right

OVER TURN SUPPORT

WB2001/ WB2002

Support capacities

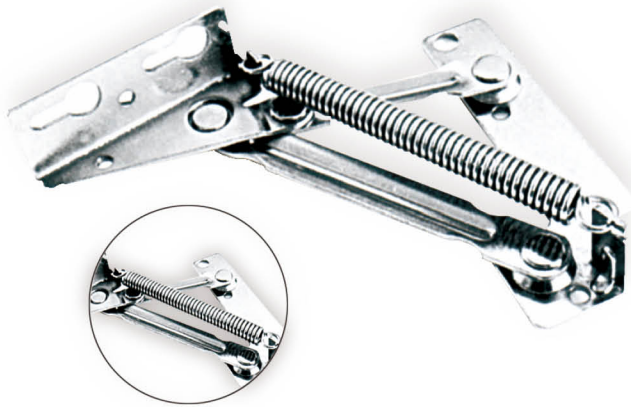

Technical specifications: WB2001

Material: zinc alloy

Color	Item No.
Nickel plated	542.116.002
Chrome plated	542.117.002



Technical specifications: WB2002

Material: zinc alloy

Color	Item No.
Nickel plated	542.116.003
Chrome plated	542.117.003

Characteristics of Products:

- 1, steel material and zinc alloy employed; chrome-plating surface processing.
- 2, desired effect can be achieved by the adjustable screws.
- 3, convenient application; multiple functions as top support and sling support.

www.meaton-group.com

D

Support Series

Support capacities



Characteristics of Products:

- 1, steel material and zinc alloy employed; chrome-plating surface processing.
- 2, desired effect can be achieved by the adjustable screws.
- 3, convenient application; multiple functions as top support and sling support.

Technical specifications: WB2003

Material: zinc alloy

Color	Item No.
Nickel plated	542.116.004
Chrome plated	542.117.004

D

Support Series

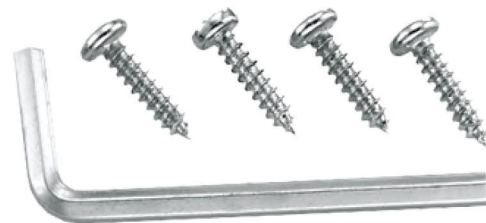

Characteristics of Products:

- 1, steel material and zinc alloy employed; chrome-plating surface processing.
- 2, desired effect can be achieved by the adjustable screws.
- 3, convenient application; multiple functions as top support and sling support.

Technical specifications: WB2004

Material: zinc alloy

Color	Item No.
Nickel plated	542.116.005
Chrome plated	542.117.005

Support capacities

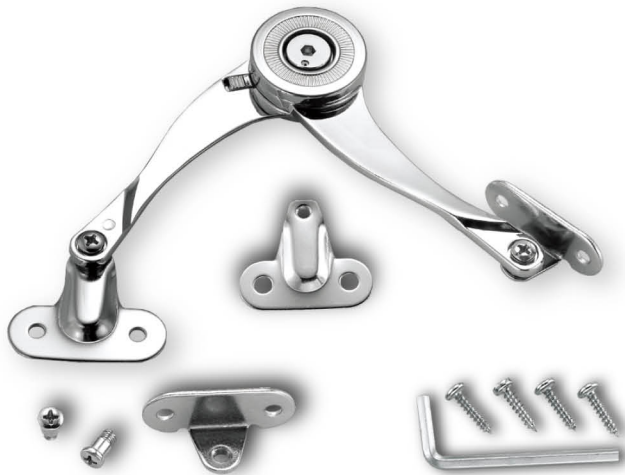

Characteristics of Products:

- 1, steel material and zinc alloy employed; chrome-plating surface processing.
- 2, desired effect can be achieved by the adjustable screws.
- 3, convenient application; multiple functions as top support and sling support.

Technical specifications :

Material: zinc alloy

Color	Item No.
Nickel plated	542.116.006
Chrome plated	542.117.006

OVER TURN SUPPORT

WB3003

Support capacities



Finish: nickel plated, chrome plated

Material: zinc alloy

Available: up-turning wooden door and aluminum-frame door

Item No.

542.116.007

Installation indication

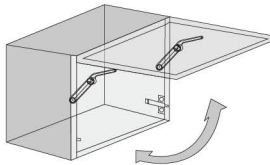

High density zinc alloy cast part, Hi-tech processing technology and surface electroplating, Hi-tech hydraulic make it silent on traveling.

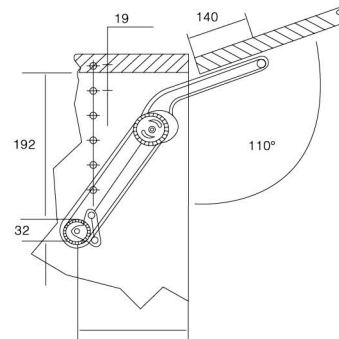
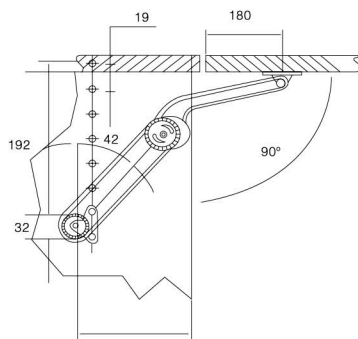
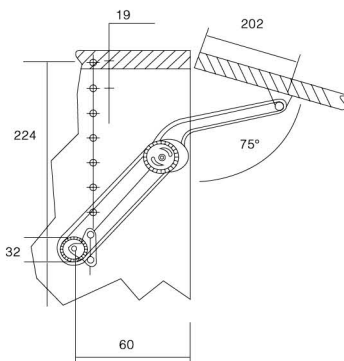
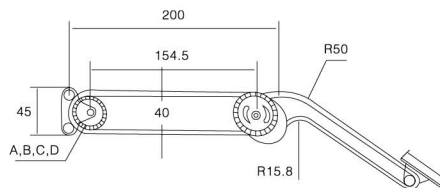
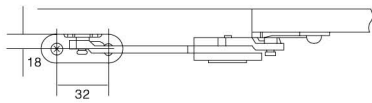

www.meaton-group.com